

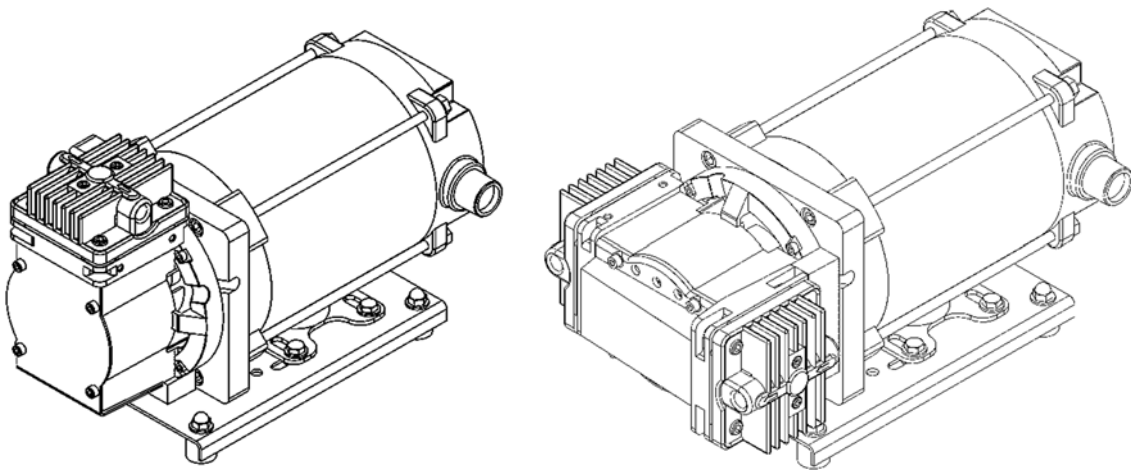

Dia-Vac® Pump Operating Instructions

Standard Hi-Vac Pump with Explosion Proof Motor



Air Dimensions Incorporated

1371 West Newport Center Drive, Suite # 101

Deerfield Beach, FL, 33442

800.423.6464 / 954.428.7333 ph.

954.360.0987 fax

info@airdimensions.com

www.airdimensions.com

General Operating Conditions

The R-Series Dia-Vac® explosion proof motors utilized by the R-Series single and double head pumps are 1/6 HP, 115V/230V, 50/60Hz single phase and are UL and CSA listed Class I, Division I, Group B, C and D, and Class II, Group F and G. This is suitable for use in Zone I Group IIB+H₂ locations. For Quad and Eight head Dia-Vac® pumps, the motor may range from 1/2 - 1 HP, and are UL and CSA listed Class I, Division I, Group C, and D, and Class II, Group F, and G.

Dia-Vac® Pumps are intended for use with gases only, do not use this product for liquids. For applications where liquid may be present in the gas stream, mount the pump so that the discharge port faces toward the ground. Mounting the pump at the highest point in the system will prevent liquid from collecting in the pump head. An elevated or steam trace heated head pump may be required to maintain the gas temperature through the head.

The Dia-Vac® Pump normally runs warm. It is not an indication of trouble if the outer surfaces of the pump or motor are hot to the touch.

The Dia-Vac® Pump normally runs quietly, especially when both pressure and vacuum ports are connected into a closed system. An obvious knock or rattle could indicate a problem. Check through "Troubleshooting" with particular attention to the tightness of all screw fasteners.

Ambient temperature of this pump should not exceed 60°C/140°F. The pump must have adequate ventilation and/or cooling to run properly.

Safety

Before running the pump, ensure that it is properly rated for the environment in which it is located. The Standard Dia-Vac® explosion proof motors utilized by the standard single and double head pumps are UL and CSA listed Class I, Division I, Group B, C, and D, and Class II, Group F and G.

All system components connected to the Dia-Vac® Pump must be capable of handling the maximum pressure of the pump.

Ensure that safety regulations are observed when connecting the pump to the electric supply. The connections are to be made in such a way that contact by any object or person with a live wire is impossible. The supply voltage must not vary more than $\pm 10\%$ of the voltage shown on the motor plate.

All proper precautions for the controlled vapor must be observed, and followed. Proper wetted materials for handling corrosive, hot, and/or reactive gases must be used.

This Dia-Vac® Pump is thermally protected; when the temperature of the pump exceeds the maximum operating temperature, pump operation will be interrupted by the thermal switch. The pump will restart automatically once it cools down. Be sure to take necessary precautions to avoid injury during restart.

Disassembly of the pump or motor beyond what is detailed in the servicing section below may result in the loss of the pump's hazardous area certification and is highly discouraged.

Operation

This pump is not designed to handle pressure of any kind. Do not run gasses higher than atmospheric pressure to the inlet of the pump. Do not obstruct the flow downstream of the pump.

No oiling or other lubrication is necessary with a Dia-Vac® pump.

If the gas stream has a high level of particulate matter, a filter should be installed before the pump. If the gas stream has a high level of liquid matter, a membrane separator should be installed before the pump. This should be in used in conjunction with best practices for pump installation including mounting the pump head so that the discharge port faces toward the ground. Keep in mind that the pump head can be rotated on the housing and the gas will always flow in the direction of the arrows.

Do not start the pump against pressure or vacuum. For applications that must start under pressure or vacuum, contact ADI and a suitable motor will be selected.

Running amps are listed on the nameplate of the motor. A pump running at a substantially higher current than shown on the motor plate indicates a problem, please see section “Troubleshooting” below. Please note that the current draw at the startup of the pump will be three to four times the normal running amps.

The diaphragm, flapper valves, sealing washer, and gasket of the pump are the only consumable parts of the pump. The degree of usage and condition of operating temperatures or pressure will determine the rate of replacement of part or parts. The corrosive content of the gas media being pumped will also affect the rate of replacement of part or parts.

The minimum performance acceptable of a Hi-Vac pump is shown in the table below. Pumps operating at 50 Hz have a 17 percent lower flow rate than their 60 Hz counter parts. To check pumping efficiency, employ suitably damped gauges connected so as to dead-head either pressure or vacuum.

Minimum Performance Requirements

Product Line	Rated Vacuum mm hg ABS	Flow (LPM) at Rated Vacuum		Open Flow LPM Minimum		Ult Vac Minimum
		Hertz		Hertz		
		60	50	60	50	
RVA1	--	--	--	30	25	25.5 in hg gauge
RVA2	35	0.25	0.21	30	25	--
RVA4	25	0.6	0.50	--	--	3.0 mm hg ABS

NOTE: Check each separately, one or the other port must be open during this test. Use a 0-30 inch Hg vacuum gauge, (or mercury manometer.)

Troubleshooting

This section lists common problems that occur, possible causes and the most common fixes. If the problem persists, the pump may require inspection at the ADI facility. To have your pump inspected and repaired at the ADI facility please follow the instructions on the ADI website at <http://www.airdimensions.com/service/rma/>.

Pump draws excessively high current

- Motor is overloaded
 - Turn off pump
 - Remove all pressure and vacuum conditions
 - Restart and test at atmospheric pressure
- Power input is incorrect
 - Check motor wiring i.e. 115 V vs 230 V wiring
 - Check power source
 - Pumps are only rated for $\pm 10\%$ voltage on name plate

Low or zero flow

- Connection or sample line blocked



- Remove blockage
- Liquid or foreign debris has collected in the head
 - Clean out the head, see section “Servicing”
 - Place pump outlet facing downward
- Diaphragms, valves, or gasket are worn
 - See section “Servicing”

Pump is rattling or knocking

- Connecting rod bolt or diaphragm plate screw are under torqued
 - See section “Servicing” for torquing specifications
- Connecting rod cap is too close to one side of housing
 - Using a screw driver lightly pry the cap away from the side of the housing and center. A centering tool is available for purchase at ADI.

Servicing

Listed below are the two predominant types of maintenance typical for Dia-Vac® Pumps, the servicing of the consumable parts (diaphragm, flapper valves, gasket, and Teflon® washer), and the servicing of the connecting rod. For video instructions on servicing the head and diaphragm visit <http://www.airdimensions.com/service/videos/>.

Disassembly of Head Section and Diaphragm

Remove head assembly by unscrewing the four head bolts. A flat-bladed screw driver may be needed to gently pry the head free of the service diaphragm.

The valve body can then be removed by unscrewing the two smaller screws (also accessible on the top of the head section). This part may be freed by gently tapping on these two screws after they have been loosened about three or four turns. There are two O-rings exposed in the head when the valve body is removed. They should remain where they are when the valve body is removed. There is no reason to remove them. If they fall out place them back in the head.

Remove the gasket from the valve body. There are two flapper valves on the valve body, one on the bottom, and one on the top. The valve on the top is protected by a valve stop. Remove the valve on the bottom and the valve stop and valve on the top. **Do not bend the flapper valves.**

As a matter of good practice, the flapper valves and gasket should be replaced during any routine maintenance check of the head section. A once a year routine procedure is recommended.

The diaphragm is secured by the single screw in its center; remove this screw. The diaphragm and its clamping plate should be easily lifted off. Some slight adherence to the metal may occur if the diaphragm has been in use for a long period.

To reattach diaphragm, first insert the diaphragm plate screw through the Teflon® washer, then through the diaphragm plate, then finally through the diaphragm. Next apply a drop of a medium strength thread locker (such as Loctite®242) to the screw. Tighten the diaphragm plate screw into the Connecting Rod Bolt. It is important that when reassembling your pump you follow the torquing specifications listed below.

NOTE: When replacing the diaphragm, be sure the four projecting studs of the base casting are properly located in the four outer holes provided in the diaphragm before the part is clamped in place. Be sure the diaphragm plate is firmly fastened with its center screw. Failure to use a thread locker may result in the diaphragm plate screw backing out, resulting in damage to the pump.

When replacing the flapper valves be careful not to bend them and make sure you replace the valve stop on top of the valve that is on top of the valve body.

If a problem occurs, the pump may require inspection at the ADI facility. To have your pump inspected and repaired at the ADI facility please follow the instructions on the ADI website at <http://www.airdimensions.com/service/rma/>.

Disassembly of the Connecting Rod

Remove head assembly and service diaphragm as described in the section above.

Using a socket wrench, remove the hex head bolt on the connecting rod top surface. This will release the connecting rod cap which may then be lifted off.

The previous two steps should be repeated for every head of the pump.

Remove the front plate (single head)/second stage housing (double and quad head) from the primary stage housing by removing the four retaining screws.

The connecting rod assembly on single head units, including the counterweight, is held in place by the counterweight screw. The connecting rod assembly may then be slid off the motor shaft. On the dual and quad head units the assembly is held in place by the set screw. This can be loosened and the assembly may then be slid off the motor shaft.

Replacement of the Connecting Rod

Replace the connecting rod assembly on the motor shaft, taking care to align set screw or counterweight screw as squarely as possible on the flat of the motor shaft.

Replace the connecting rod cap and connecting rod bolt. Tighten this assembly to 150 in-lbs. using a torque wrench.

Related Torque Values

Head bolts - 110 in-lbs.

Valve body screws and Diaphragm plate screws - 70 in-lbs.

Connecting rod bolt - 150 in-lbs.

Spare Parts

Kit #	Description
11012	KIT, REPAIR - TEFLON®/EPDM
11014	KIT, REPAIR - ALL TEFLON®

For a complete list of spare parts please follow the following links:

Single Head Pump:

http://airdimensionscom.c.presscdn.com/wp-content/uploads/2014/11/RVA1-Fx-AC5_Part2.pdf

Double Head Pump:

http://airdimensionscom.c.presscdn.com/wp-content/uploads/2014/11/RVA2-Fx-Axx_Part2.pdf

Quad Head Pump:

http://airdimensionscom.c.presscdn.com/wp-content/uploads/2014/11/RVA4-Fx-Axx_Part2.pdf

Warranty

All Air Dimensions Incorporated Dia-Vac® Pumps are under warranty for 12 months from the ship date. The warranty does not cover consumable parts (diaphragm, flapper valve gasket, and Teflon® washer). For complete terms and conditions please see Appendix B.

Appendix A- Maximum Gas Temperature for ADI Diaphragms

<u>Diaphragm Material</u>	<u>Max Temperature</u>	<u>Comments</u>
Teflon Coated EPDM	250 °F (121 °C)	Not available in J-Series
EPDM	250 °F (121 °C)	Not available in J-Series, H-Series
Viton	400 °F (205 °C)	Not available in J-Series, H-Series
Teflon/Viton	400 °F (205 °C)	J-Series Only
All Teflon	400 °F (205 °C)	

Appendix B- TERMS AND CONDITIONS OF ACKNOWLEDGMENT OF ORDER

1. **EXCLUSIVE REMEDY.** Seller will replace or, at its option, repair any products or parts thereof which are found defective by Seller in material or workmanship within one year from date of shipment, provided the product has been properly installed, maintained and operated. Seller's obligation with respect to such products will be exclusively limited to repair or replacement F.O.B. Deerfield Beach, Florida, U.S.A., and in no event shall Seller be liable for consequential or special damages, or for transportation, installation, adjustment, or other expenses which may arise in connection with such products. **NO EXPRESS WARRANTIES AND NO IMPLIED WARRANTIES WHETHER OF MERCHANTABILITY OF FITNESS FOR ANY PARTICULAR USE, OR OTHERWISE (EXCEPT AS TO TITLE), SHALL APPLY TO PRODUCTS SOLD BY US, AND NO WAIVER, ALTERATION, OR MODIFICATION OF THE FOREGOING CONDITIONS SHALL BE VALID UNLESS MADE IN WRITING AND SIGNED BY AN OFFICER OF SELLER.**
2. **METHOD OF SHIPMENT.** This apparatus will be shipped "knocked down" to the extent we consider necessary for proper shipment with small parts.
3. **SHIPMENT.** All goods are shipped F.O.B. shipping point which shall be Deerfield Beach, FL unless otherwise specified. Risk of loss of damage to goods in transit shall fall upon Buyer.
4. **TERMS.** Subject to any prior written agreement to the contrary, and to approval of credit, payment for products shall be made Net 30 days from date of invoice. If in Seller's opinion the financial condition of Buyer does not justify continuance of production or shipment on the terms of payment specified, Seller may, at its option, require full or partial payment in advance. Seller reserves the right to issue an invoice if shipment is delayed due to Buyer's responsibility, request or if partial shipment occurs. Goods held for Buyer shall be at the risk and expense of Buyer. All bank and collection charges are for Buyer's account.
5. **TAXES.** In addition to the purchase price, Buyer shall pay or upon receipt of invoice from Seller shall reimburse Seller for all sales, use, occupation, gross income, excise, documentary stamp, and other taxes, assessed or imposed by Purchaser, or on the machine as required to be collected by Seller, by reason of or on account of the delivery, purchase, or sale of any article here under or the execution of this contract.
6. **PATENT INDEMNITY.** Buyer shall indemnify and hold Seller harmless against any loss, liability or expense, including reasonable attorney's fees, resulting from infringement or patents or trademarks arising from compliance with Buyer's design, specifications or instructions. Upon notification by Seller, Buyer shall at its sole expense undertake the complete defense of all lawsuits or other proceedings brought under this paragraph. Buyer agrees that it will not reproduce any of the aforementioned equipment in whole or part for the purpose of use or resale or for any other purposes without the Seller's written consent.
7. **DELAYS.** Shipping dates are approximate and are based upon prompt receipt of all necessary instructions and information which will enable Seller to immediately start shop construction. Seller shall not be liable for delay in delivery due to causes beyond its reasonable controls such as acts of God, acts of Buyer, acts of civil or military authority, priority, fires, strikes, floods, epidemics, quarantine restrictions, war, riot and delays in transportation. In the event of delay due to such causes, the date of delivery shall be extended for a period equal to the time lost by reason of delay. If by reason of any of the foregoing events or conditions shipment is delayed more than one year beyond the period specified herein, either party may terminate this contract by written notice to the other, and in that event Seller shall return to Buyer all payment previously made hereunder without interest.
8. **STANDARD PRICES.** Prices shown are standard to Industry and U.S. government for a like quantity and model.
9. **CLAIMS.** All claims must be made in writing within 30 days of receipt of goods; otherwise such claims shall be deemed waived and released by Buyer.
10. **DEFAULT.** In the event of a default by Buyer, Seller may, in addition to all other remedies it may have as a result of such default, elect to retain any and all payments made by Buyer hereunder as liquidated damages.



11. **RETURN OF GOODS.** No materials shall be returned without authorization and shipping instructions first being obtained from Seller. Unless Seller specifically and expressly agrees otherwise, freight forwarding, transportation and other associated shipping costs and customer clearance charges shall be paid by Buyer.

12. **CONTROLLING PROVISIONS.** These terms and conditions shall supersede any provisions, terms and conditions contained on any purchase order, or other writing Buyer may give or have given, and the rights of the parties shall be governed exclusively by the terms and conditions hereof.

13. **MERGER CLAUSE.** This writing constitutes the final expression of the parties' agreement, and it is a complete and exclusive statement of the terms of that agreement. The terms and conditions herein contained shall supersede all prior oral or written statement of any kind whatsoever made by Seller or its representative.

IMPORTANT

This merchandise was carefully packed and thoroughly inspected before leaving our factory. Responsibility for its safe delivery was assumed by the carrier upon acceptance of the shipment. Claims for loss or damage sustained in transit must, therefore, be made upon the carrier as follows:

CONCEALED LOSS OR DAMAGE

Concealed loss or damage means loss or damage which does not become apparent until the merchandise has been unpacked. The contents may be damaged in transit due to rough handling even though the carton may not show external damage. When the damage is discovered upon unpacking, make a written request for inspection by the carrier's agent within fifteen days of the delivery date. Then file a claim with the carrier since such damage is the carrier's responsibility. By following these instructions carefully, we guarantee our full support of your claims to protect you against loss from concealed damage.

VISIBLE LOSS OR DAMAGE

Any external evidence of loss or damage must be noted on the freight bill or express receipt, and signed by the carrier's agent. Failure to adequately describe such external evidence of loss or damage may result in the carrier refusing to honor a damage claim. The form required to file such a claim will be supplied by the carrier.

**DO NOT RETURN DAMAGED MERCHANDISE TO US
FILE YOUR CLAIM AS ABOVE**